

Table of contents	Page	2
Product features	3	
Applications-----	3	
Installation-----	4	
Operation-----	4	
Limitations-----	4	
Communication via Intercontrol Terminal Program-----	5	
Instructions for safe use-----	6	
Appendix A :: Specifications-----	7	
Appendix B :: Dimension diagram-----	8	
Appendix C :: Connection diagram-----	8	
Appendix D :: Product order codes-----	8	
Revision history-----	9	

Appendix E :: Modbus addresses (see separate Modbus document).

Table of figures

Figure 1 :: Process mounting of the LTI-02	4
Figure 2 :: Intercontrol Terminal software	5
Figure 3 :: Labelling on the LTI-02	6
Figure 4 :: Dimension diagram of the LTI-02	8
Figure 5 :: Connection diagram of the LTI-02	8



Disclaimer

Information found in this document is used entirely at the reader's own risk and whilst every effort has been made to ensure its validity Intercontrol Meet- en Regeltechniek BV make any warranties with respect to the accuracy of the information contained herein.



The Intercontrol LTI-02 is a non-contact instrument for automatically measuring the level of bulk, granular solid materials in silos and other storage vessels.

Based on laser technology with its characteristic narrow beam and low divergence, the LTI-02 can measure directly to a surface without interference from internal structure and with complete immunity to surface angle or material dielectric.

Product features

- integral alignment flange
- integral dust protection
- measures to the bottom of a silo
- narrow beam with low divergence
- can be configured without filling or emptying the vessel
- air purge to keep lenses free from dust

The LTI-02 sensor features an integral flange and swivel joint which is adjustable through an angle of $\pm 10^\circ$ making it easy to aim to the very bottom of a silo. The unit can measure all clearly visible surfaces irrespective of texture, granularity, slope or colour. A still-air barrier prevents dust particles from reaching the optics and keeps the lenses clean for long periods. The LTI-02 has a USB port that can be used to input configuration and settings.

This port also supplies power to the instrument in the event that field power is not available.

Applications

The LTI-02 accurately measures to the surface of mineral ores, grains, fibrous materials, synthetic plastics and numerous other materials that are stored in bulk, pellet or granular forms.

By taking advantage of its long measuring range and narrow beam, the LTI-02 can reach the bottom of tall silos or measure through narrow apertures into feed chutes, bunkers and hoppers.



Simplifying solid level measurement

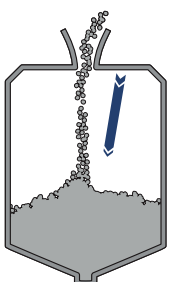

Level control

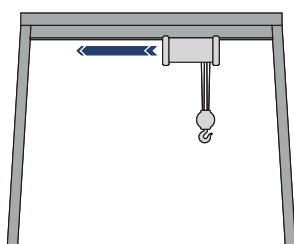

Positioning

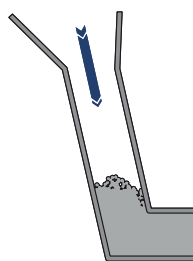

Blocked-chute detection

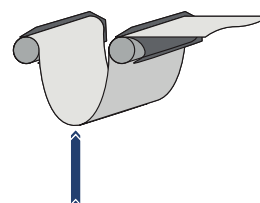

Break, tear & slack monitoring

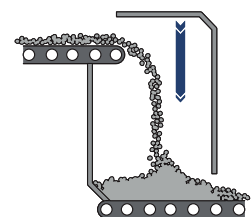

Build-up monitoring

Installation

The LTI-02 is normally attached to a process connection at the top of a silo or mounted on a bracket above the material to be measured.

To aim the LTI-02 at the right point on the surface or down to the bottom of a silo, loosen the clamp ring on the adjustable flange and rock the body of the instrument to the correct angle.

Tighten the clamp ring to re-seal the process.

In dusty environments the 1/8" BSP plastic cover on the clamp ring can be removed to free this connection for external air supply.

This air flow will blow dust away from the lenses in to the silo.

The LTI-02 nominally uses 24 V DC field power and produces a 4...20 mA current Output which is powered from the same source.

Internal testing verifies the continuity of the current output and the status can be viewed on a terminal device using the USB port.

If field power is not available, the USB interface can still be used to test, align and put settings into the instrument making use of power that is supplied through the USB port.

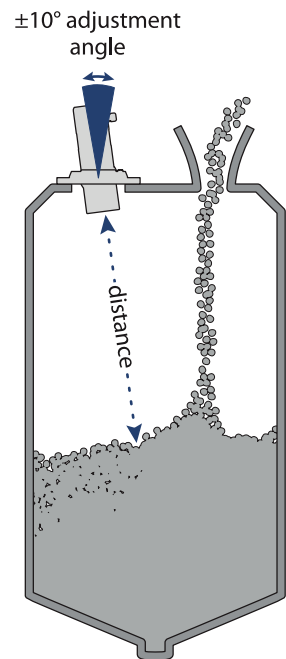

Figure 1: Process mounting of the LTI-02

Operation

The LTI-02 continuously outputs a current on the NAMUR compliant 4...20 mA channel, that is proportional to the level of the material being measured. Accurate determination of this level is the result of multiple sensing technologies feeding into a mathematical algorithm.

The resulting vertical measurement is transformed into the final level by using the absolute distances input as the 4...20 mA end points.

As an alternative for the 4-20 mA output the LTI-02 unit has Modbus RS485 communications. Multiple sensors can be wired with just one cable to the control room.

Limitations:

The LTI-02 includes filtering algorithms that remove interference from light or sporadic dust, vapours or falling materials.

However, if there is too much dust or the vapour is too opaque the readings will be affected.

Setup & Communication via Intercontrol Terminal

CAUTION

The LTI-02 contains a laser and should never be aimed at a person or an animal. Do not look at the beam directly with optical instruments.

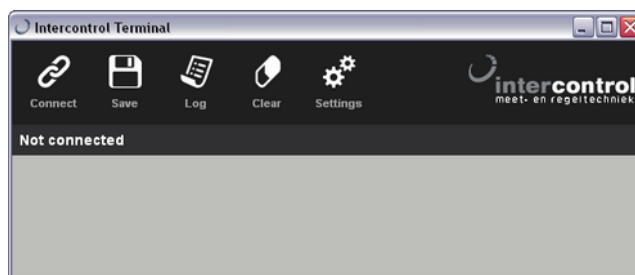

Figure 2 :: Intercontrol Terminal software

- Install the latest revision of Intercontrol Terminal software. Everything needed for communicating with LTI-02 will automatically be installed.
- Connect the LTI-02 to a PC using a USB cable. The power indicator LED in the LTI-02's terminal compartment will light up.
- Open the Terminal software on the PC, a connection with the LTI-02 will automatically be established using baud rate of 115200,8,n,1.
- Click the "Connect" icon to open a communications port. The distance measurements should begin to scroll in the Terminal window as follows:

- 1.79 m --.-- mA 100 %
- 1.79 m --.-- mA 100 %
- 1.79 m --.-- mA 100 %

Distance in m 4...20 mA output signal strength

If an automatic connection is not created, click the "Settings" icon and select the appropriate USB port and 115200 baud rate.

- To access the configuration settings menu of the LTI-02, press the <SPACE> keyboard key. In case of password protection press the <SPACE> keyboard key and type 12345 on the keyboard and the config menu will appear. Press the appropriate keyboard key to select a menu item, e.g. type <A> for "a: Hide 4-20 mA settings" to show or hide the 4-20 mA settings menu.
- To restart measurements, press the <SPACE> keyboard key. To save a copy of the current screen data, click the "Save" icon.

Setting	Example	Description
a: Hide 4-20 mA settings		
b: 4 mA distance setting	25.00 m	Enter the distance that corresponds to the 4 mA output value.
c: 20 mA distance setting	0.60 m	Enter the distance that corresponds to the 20 mA output value.
d: 4-20 mA fail safe current	>21.0 mA	Enter the failsafe condition of the 4...20 mA range for alarm indications.
e: 4-20 mA test	19.22 mA	Test the 4...20 mA output
n: Hide system settings		
o: Measuring units	meters	Enter the required measuring units
p: Zero distance offset	0.00 m	Enter the zero datum trim
q: Lost signal timeout	4.0 sec	Enter the lost signal hold time delay.
r: Smoothing filter	ON	Turns the smoothing filter OFF (raw) or ON (filtered). This filter attempts to remove rapid changes of distance by smoothing one distance measurement to the next.
s: Filling rate filter	OFF	Turns the filling rate filter OFF or ON.
u: Moving obstacle filter	ON	Turns the moving obstacle filter OFF or ON. This median filter operates on the last "v: Obstacle filter size" distance measurement.
v: Obstacle filter size	16 results	Select the number of obstacle distance measurements results to be rejected. This number is used for the setting "u: Moving obstacle filter".
---- Press <space> to run ----		

- If you wish to start recording data, click the "Log" icon.
- To clear the screen of measurement data, click the "Clear" icon.
- Once you have configured the LTI-01, click the "Disconnect" icon and disconnect the USB cable from the unit.

Instructions for safe use

The LTI-02 is a laser rangefinder that emits ionizing laser radiation. The level of the laser emission is Class 1M which indicates that the laser beam is safe to look at with the unaided eye but must not be viewed using binoculars or other optical devices at a distance of less than 0.05 meters. Notwithstanding the safety rating, avoid looking into the beam and switch the unit off when working in the of less than 0.05 meters. Notwithstanding the safety rating, avoid looking into the beam and switch the unit off when working in the area.

CAUTION -- The use of optical instruments with this product will increase eye hazard.

The LTI-02 should not be disassembled or modified in any way. The laser eye safety rating depends on the mechanical integrity of the optics and electronics so if these are damaged do not continue using the LTI-02. There are no user serviceable parts and maintenance or repair must only be carried out by the manufacturer or a qualified service agent.

No regular maintenance is required for the LTI-02 but if the lenses start to collect dust then they may be wiped with suitable lens cleaning materials.

Make sure that the LTI-02 is switched OFF before looking into the lenses.

Laser radiation information and labels

Specification	Value / AEL	Notes
Laser emission wavelength	905 nm	
Maximum average radiant power	20 mW	
Laser output	Pulsed	
Pulse repetition rate	36 kHz	
Beam divergence	0.2°	
Nominal Ocular Hazard Distance and Area	0.05 m	Distance beyond which binoculars with may be used safely



Figure 3: Labelling on the LTI-02

Appendix A: Specifications

Performance data		
Sensing range	0,3...50 m	
Resolution	10 mm	
Accuracy	1 standard deviation = 2,5 cm at 20°C	
Update rate	8 readings per second	
Technical data		
Analog	4...20 mA NAMUR compliant self-powered & non-isolated	
Filing rate	0,01 ... 100 m/min	
Power supply	24 V DC nominal (12...28 V DC)	
Communications	USB 115200 baud 8-N-1 and Modbus RTU RS485 2-wire	
Mechanical data		
Dimensions	Diameter: 220 mm with standard DN100 flange	Length: 206 mm
Weight	1,6 kg	
Process connection	Flange	
Electrical connection	M16 x 1,5 (2x)	
Air purge hole	1/8" BSP option	
Environmental data		
Pressure	Atmospheric	
Operating temperature	-20°C...+60°C	
Enclosure rating	IP 66	
Materials		
Housing	Anodized aluminium	
Lenses	Impact resistant acrylic	
Laser		
Optical aperture	60 mm	
Laser power	20 mW	
Beam divergence	< 1° to half power points	
Laser safety classification	Class 1M	
CAUTION	Do not view laser directly with optical instruments	
Approvals		
	 <small>0513</small>	

Filter explanations:

Smoothing filter: Smooths out the distances results so that small changes have little effect, but big changes will still affect the result. This is much like an averaging filter and helps to increase accuracy on slow moving targets.

Moving obstacle filter: This filter can eliminate big changes in distance that only last for a short time. For example, if something moves in front of the laser and target for a short time then it will be completely ignored.

Obstacle filter size: This filter controls how long the obstacle can be in front of the laser before it reacts. This can also help with dust and other effects that can appear as obstacles moving in front of the laser.

Password Protection:

Since serial number 14500 the software can be password protected.
To activate password protection select 'on' at the password question.
The standard (non-editable) password is 12345

Appendix B: Dimension diagram

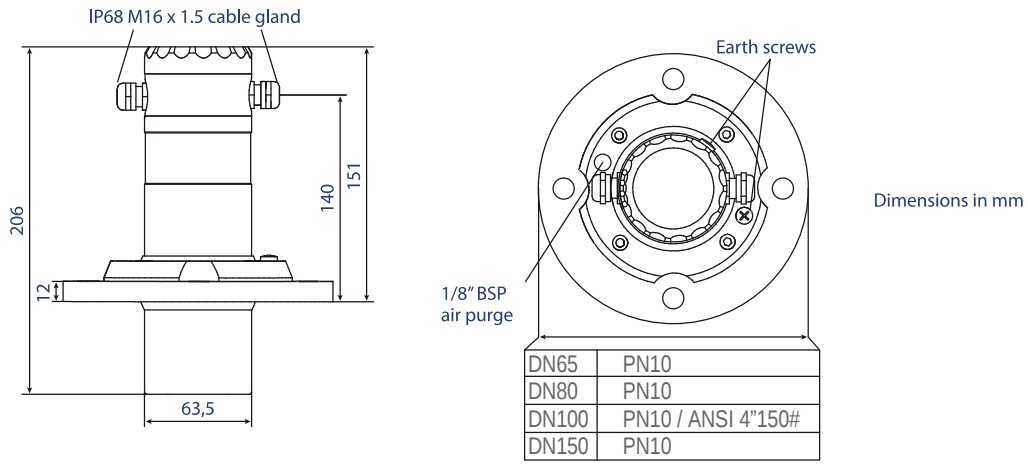

Figure 4 :: Dimension diagram of the LTI-02

Appendix C: Connection diagram

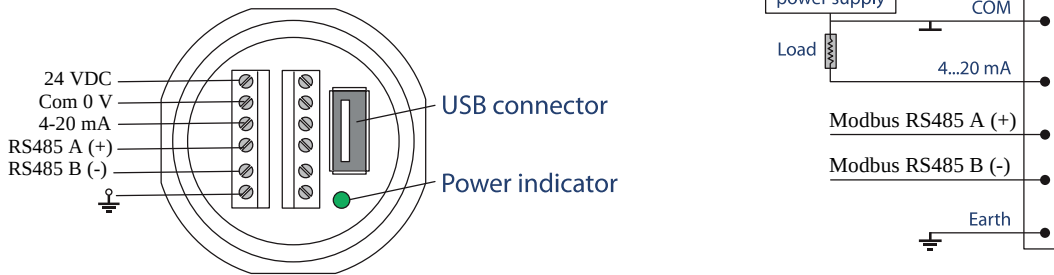

Figure 5 :: Connection diagram of the LTI-02

Appendix D :: Product order codes

- LTI-02 Non-contact level measurement sensor
- LTI-02/NW65 Sensor with swivel flange NW65 PN10
- LTI-02/NW80 Sensor with swivel flange NW80 PN10
- LTI-02/NW100 Sensor with swivel flange NW100 PN10 and ANSI 4" 150 #
- LTI-02/NW150 Sensor with swivel flange NW150 PN10

Requested flange size to be added according to PN10 or ANSI rating.
Pressure rating only valid for the flange dimensions.
Max pressure for the laser is atmospheric.

Revision history

Version	Date	Authors	Comments
Rev. 6	2023/10/17	RP	Added Modbus communications in Manual. Added Modbus specifications in Appendix E. Updated connections drawing.
Rev. 5	2018/11/05	TLP	Updated Appendix B and Appendix D to include pressure rating for the flanges (page 8). Updated descriptions for "r: Smoothing filter", "u: Moving obstacle filter", and "v: Obstacle filter size" (page 5).
Rev. 4	2016/06/27	TLP	Branding changes to document and inclusion of "Table of contents", "Table of figures", and "Disclaimer" (page 2). Updated the "Communication via Intercontrol Terminal" section to reflect updated software menu structure (page 5). Updated the "Instructions for safe use" section (page 6). Removed Imperial measurements in "Appendix A :: Specifications" (page 7) and "Dimension diagrams" (page 8). Included "Appendix D :: Product order codes" (page 8). Updated photographs to reflect new product housing paint colour (pages 1, 2, 3 & 6).
Rev. 3	2016/05/25	TLP	Branding changes to document and inclusion of a cover page, which change page numbering throughout (page 1). Added new section "Communication via Intercontrol Terminal" (page 4). Included new section "Laser safety" (page 5). Included new section "Service and maintenance" (page 5).
Rev 2	2013/05/26	TLP	Include the bullet "air purge to keep lenses free from dust" unto the "Product features" section (page 1). Updated the "Technical specifications" to include "Connections" NW80 flange with 4 Ø 16,5 mm (0,63") holes on 150 PCD and NW100 flange with 4 Ø 16,5 mm (0,63") holes on 170 PCD", and "Air purge hole 1/8" BSP" (page 1). Updated the "Dimension drawings" to include additional connection flanges options (page 2). Updated "Product order codes" to include additional flange options (page 2).
Rev 1	2013/05/06	TLP	Included CE approval mark to "Technical specifications" table (page 1).
Rev 0	2013/01/30	JEP	Initial release of document.