

FlowSwitch FS 510

Continuous flow monitoring
for bulk materials



NEW: ATEX Option



Application

The FlowSwitch FS 510 is monitoring the conveying stream of solids.

It is a robust microwave-based flow / no-flow switch and detects failures and problems during the transport or feeding of powders, dust, pellets or granules. This helps to prevent serious difficulties that can occur due to clogged piping, material loss, or other technical problems with the conveying system. The compact device can be used wherever monitoring of bulk solids movement is required.

Scope of use

| | |
|------------------------|-----------------------|
| Animal feed industry | Minerals |
| Building materials | Pharmaceuticals |
| Cement industry | Pigment production |
| Production of ceramics | Plastic manufacturing |
| Chemical industry | Power plants |
| Coating processes | Recycling industry |
| Detergent industry | Rubber goods |
| Food industry | Synthetic materials |
| Foundries | Textiles |
| Glass production | Wood & Pellets |
| Lime plants | etc. |
| Metal production | |

Main Benefits

- Reliable, contactless microwave measurement
- Works within several meters distance
- Does not interfere with the material
- Very sensitive and flexible with adjustable amplification, filter, hysteresis, delay, min/max
- Compact and easy to install and retrofit
- Wear- and maintenance-free
- Robust stainless steel design
- 100% safe operation with active self-monitoring
- ATEX protection (optional up to zone 20/21)

Function

The FlowSwitch FS 510 is based on modern microwave technology. If material passes the sensor, the emitted microwaves are reflected. This is converted into a switching process.

The sensor can be installed within pipes, on conveying belts, fall plates, chutes or at similar transport facilities. It allows safe identification of flow / no-flow, inadequate or missing material, plugs, blockage or standstill – from several meters distance. It does not impact the bulk material and is wear- and maintenance-free.

All parameters, like sensitivity, damping, filter time and hysteresis are adjustable, and the sensor can easily be adapted to any use.

The FlowSwitch FS 510 is known as the most robust flow monitor of its class. It is made of stainless steel and optimized for a long lifetime. High ATEX ratings and adapters for high pressure allow use in the most difficult environment.

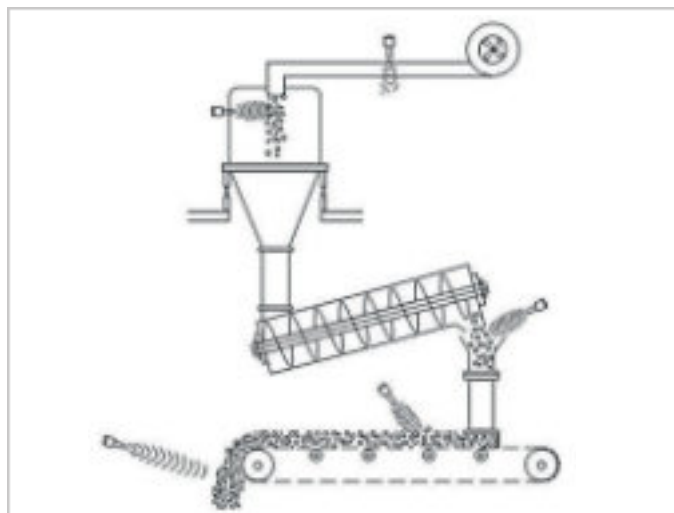

Technical Data

| | |
|----------------------|-------------------------------------------------------------------------------|
| Housing material | Stainless steel (1.4307) |
| Sensor surface | Teflon (optional ceramic) |
| Ambient temperature | -20°C to +60°C |
| Process temperature | -20°C to +85°C |
| Process pressure | 6 bar (optional 30-60 bar) |
| Protection class | IP65 |
| Ex protection / ATEX | Optional up to Zone 20/21 |
| Power supply | 24 VDC (18 - 30 VDC) |
| Current consumption | Ca. 80 mA at 24 VDC |
| Transmitting power | 10 dBm |
| Output (switching) | 1x Relay contact (change-over contact, potential free) 1x NO ready contact |
| Switching voltage | 30 VAC or 30 VDC |
| Switching current | min. 10 µA & max. 2 A |
| Switching power | 30 VA or 30 W |
| Electr. connection | Plug-in screw terminals |
| Adjustable parameter | Amplification, filter, hysteresis, delay, min / max switches |
| Parameterization | Direct at device via buttons |
| Indicators | LED green (working) LED yellow (switch) |

Bar

graph

