

MX 06 – ¼” DIGITAL FLOW METERS

SUITABLE FOR FLOW RANGE 0.5-100L/HR



MX06P-1SE
Stainless steel body with LCD register

Output variations:



B -Ex approved (Ex ia)
Intrinsically Safe -NPN
N -Ex approved (Ex ia)
Intrinsically Safe -NAMUR
T -High Temperature
Max temp-150°C



F -ER
LCD Display (17mm)
G-ERA
LCD Display (17mm)
H-ERB
LCD Display (17mm)
Batch controller



D -PR
LCD Display (12mm)
E -PRA
LCD Display (12mm)
with outputs



A -Standard Pulse
Reel/Hall Effect
I -Standard Pulse
Reel/Reed Effect
J -Standard Pulse
Hall/Hall Effect
K -High Resolution
Hall NPN

The MX06 ¼” Digital Flow Meters are suitable for flows between 0.5-100L/hr. The ¼” Digital Flow Meters have an accuracy of +/-0.5% and provides exceptional levels of reliability and durability.

SPECIFICATIONS

	MX06F	MX06S	MX06P
Materials of Construction Meter Body	Aluminium(6061)	Aluminium(6061)	Stainless Steel (316)
Rotor	PPS	Stainless Steel (316)	PPS Stainless Steel (316)
Seals	Fluorocarbon(FKM)	PTFE Encapsulated(FEP)	PTFE Encapsulated(FEP)
Design Specifications Process Connections	¼” G ¼” NPT	¼” G ¼” NPT	¼” G ¼” NPT
Technical Specifications Flow rate	<5cP 2-100L/hr 0.5-26USG/hr	>5cP 0.5-100L/hr 0.13-26USG/hr	<5cP 2-100L/hr 0.5-26USG/hr >5cP 0.5-100L/hr 0.13-26USG/hr
Non-lubricating fluids	6-100L/hr 1.58-26USG/hr	6-100L/hr 1.58-26USG/hr	6-100L/hr 1.58-26USG/hr
Operating Temperature Range*	-40 -80°C -40 -176°F	-40 -120°C -40 -248°F	-40 -80°C (150°C with high temp. rotors) -40 -176°F (302°F with high temp. rotors)
Max. Operating Pressure	1000psi 69bar	1000psi 69bar	1000psi 69bar
Accuracy	+/-0.5%	+/-0.5%	+/-0.5%
Repeatability	+/-0.03%	+/-0.03%	+/-0.03%
Nominal K-Factor	1000 Pulses/L	1000 Pulses/L	1000 Pulses/L

*Temperature based on standard pulse output -subject to change dependant on rotor and output type, contact Macnaught technical support for further investigations

OUTPUTS TYPES

	DESCRIPTION	SWITCH TYPE	OUTPUT TYPE	MX06F	MX06S	MX06P
X	No Output	-	No Output	●	●	●
A	Standard Pulse	Reed /Hall (NPN)	Pulse (1m flying lead)	●	●	●
B	Ex approved (Ex ia)	Hall (NPN)	Pulse (2mDIN cable)	—	●	●
D	PR (LCD 12mmdisplay)	-	Display 12mm	●	●	●
E	PRA (LCD 12mmdisplay)	-	Display 12mm,4-20mA output,Pulse	●	●	●
F	ER (LCD 17mmdisplay)	-	Display 17mm	●	●	●
G	ERA (LCD 17mmdisplay)	-	Display 17mm,4-20mA output,Pulse	●	●	●
H	ERB (LCD 17mmdisplay)	-	Display 17mm + Batch Control	●	●	●
N	ExApproved (Exia NAMUR)	NAMUR	Pulse (2mDIN cable)	—	●	●
T	High Temperature	Hall (NPN)	Pulse	✗	S	S
I	Reed/Reed	Reed/Reed	Pulse (1m flying lead)	—	—	—
J	Hall/Hall	Hall/Hall	Pulse (1m flying lead)	—	—	—
K	High Resolution (omnipolar)	Hall (NPN)	Pulse (1m flying lead)	—	—	—

● Available ✗ Not Available S Only with stainless steel rotors — Consult Macnaught Technical regarding availability

DIMENSIONS

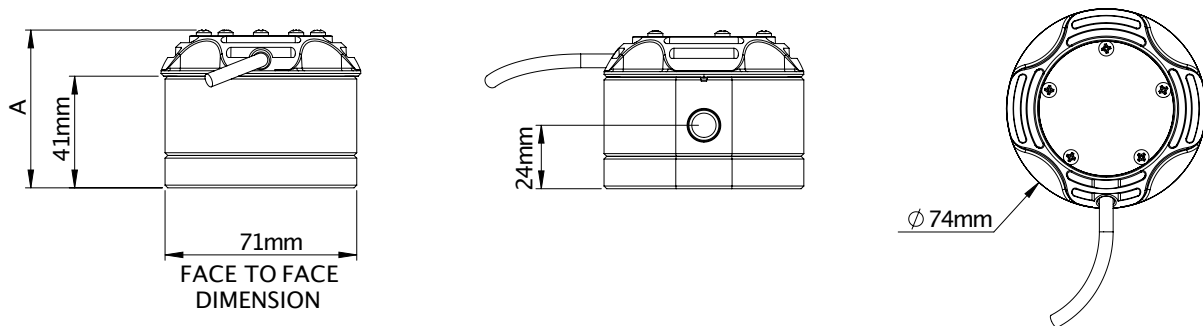

PULSER AND DISPLAY HEIGHT -A

