

HUMY 3000

Continuous inline moisture measurement of bulk materials



Application

The moisture in solids is an important parameter which strongly influences the quality of the product and the efficiency of the production. However, the common measurement method is still the examination of samples in the laboratory, which is time-consuming and the results of which are only available with a delay.

Our inline moisture measurement system HUMY 3000 is the better alternative. It allows immediate reaction to moisture changes, e.g. by regulating a dryer, an automatic humidification system or other process parameters. It is equipped with a local control unit, and can be operated with or without connection to a PLC.

Scope of use

Animal food
 Building materials
 Chemical industry
 Coal processing
 Fertilizer industry
 Food industry
 Metal processing
 Pharmaceuticals
 Plastics
 Power plants
 Pulp and Paper
 Recycling
 Steel industry
 Tobacco
 Wood
 etc.



HUMY 300/3000
 Continuous inline moisture measurement

MF 3000
 Microwave mass flow measurement

FS 510
 Microwave material flow monitoring

FS 600
 Electrostatic material flow monitoring

FS 700/710/750
 Triboelectric dust monitoring

LC 510
 Microwave barrier and limit level monitoring

Main Benefits

- Continuous and exact real-time recording of moisture
- No waiting time for time-consuming lab sampling
- Ensures the product contains not more or less than the maximum permissible water content, therefore improves product quality and reduces production costs
- Saves energy during drying
- Most accurate device of its class, accuracy up to 0,1 % (depending on the product)
- Measures total water content, not only the water on the surface
- Very robust, suitable for a harsh environment
- Encapsulated sensor with vibration-proof design, can even be used in vibration channels
- Best ATEX-rating (dust zone 20 and gas zone 0)
- Easy mounting and retrofit on conveyor belts, screw conveyors, pipes, chutes, etc. with multiple fixtures
- User-friendly operation directly at the device
- Integrated data logger and multiple in-/outputs

Function

The HUMY 3000 is a capacitive measuring system. This offers numerous advantages, e.g. compared to NIR sensors (sensitive to ambient light and contamination) and microwave sensors (limited at high humidity). The basic principle of the measurement is simple: The sensor of the HUMY 3000 generates an electromagnetic field. During the measurement, the relative permittivity and the high-frequency recession of the solid is measured in the high-frequency range. Since the permittivity of water and most bulk solids are very different, the water content of a material can be indirectly deduced from this.

The HUMY 3000 takes readings of its sensor in real

time. The result represents the total water content of a material – not only of the surface, as the sensor penetrates material up to 200 mm deep. For best results, the measurement should happen in contact with the material and while it is flowing and passing the sensor.

The measurement has an accuracy of up to 0,1 % depending on the bulk material. It is not impacted by changes of electrical conductivity, pH value, surface structure, color, steam, dust or by foreign light. The density, height and velocity of the material should be kept constant. Multiple calibrations can be taken and saved for different materials or material characteristics.

Examples for installation

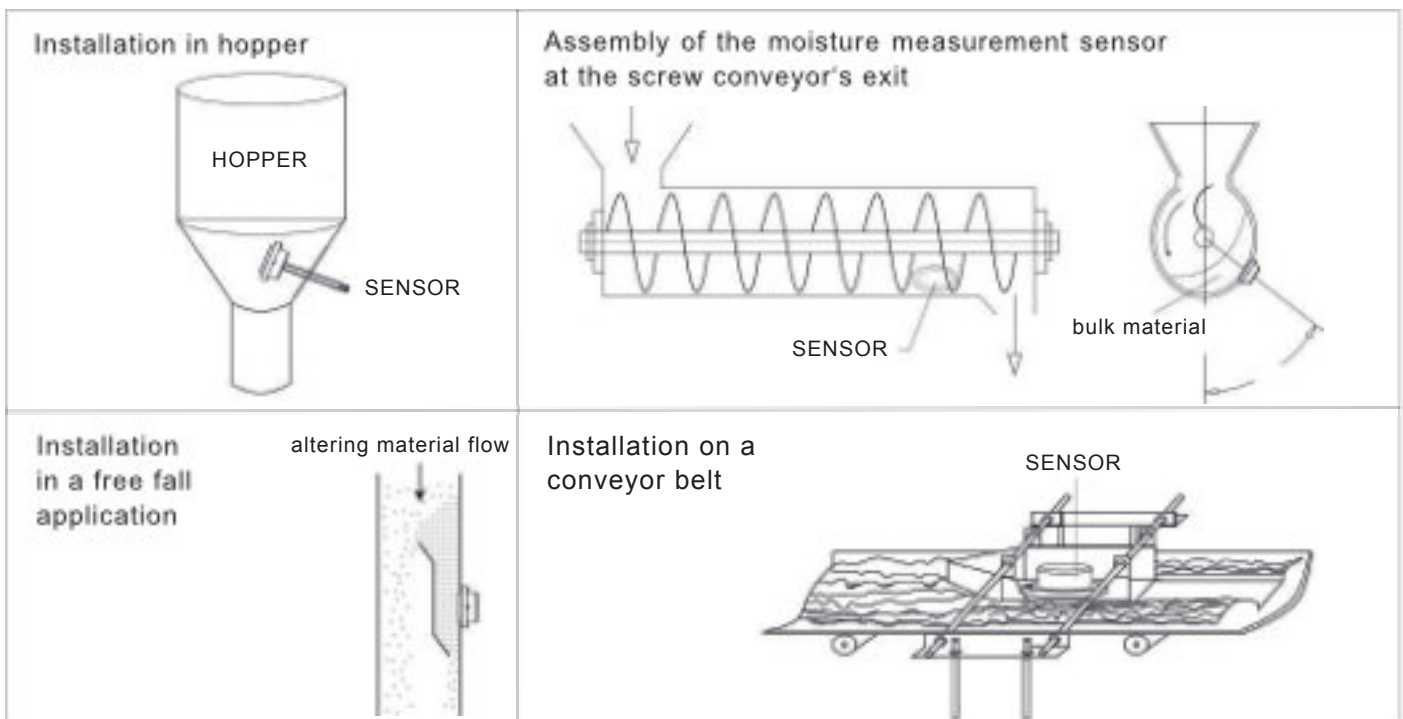

Features

The sensor of the HUMY 3000 is very robust and flexible. A sensor surface out of POM, Teflon or ceramic is available to handle abrasive or aggressive materials. A high temperature and an ATEX option for zone 20 or zone 0 are available. The device is equipped with two analog outputs for moisture and temperature, a relay for alarm signals and a RS485 Modbus interface. Calibration can be done at the device, up to 24 data sets can be stored. A Datalogger for up to 2 years of data is integrated and the stored data can be downloaded to a Windows software.

The whole device is optimized for reliability and long lifetime. Each sensor is sealed and tested under extreme

temperatures. A self-monitoring function supervises the device itself. Therefore, it is no surprise that HUMYs are used in the most extreme environments, e.g. vibration channels.

The HUMY 3000 can be connected to up to 8 moisture sensors, and all of them are visualized in the same software. This makes operation a joy. Furthermore, it is possible to connect other sensors with the device, e.g. the mass flow sensor of the MF 3000 – it is an universal measurement solution.

Successful installations (extract)



Wheat / Corn



Malt



Sugar beet



Gelatine



Powdered milk



Animal food



Cement



Sand



Limestone



Fertilizer



Wood pellets



Cellulose



Plastic granulate

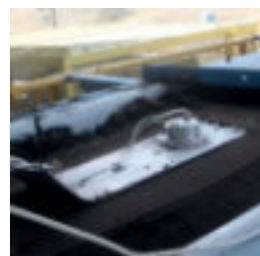

Coal & coke iron ore

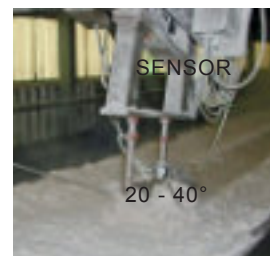

Aluminium oxide

Technical Data Sensor

Housing material	Stainless steel (1.4301 or 1.4307 as option)
Sensor surface	K = POM C = Ceramic (optional) T = Teflon (optional) S = Ceramic+Teflon (optional)
Ambient temperature	0°C to +70°C (K/C vers.) 0°C to +80°C (T/S vers.)
Process temperature	0°C to +90°C (Non ATEX) 0°C to +120°C (Non-ATEX with high temperature option) 0°C to +70°C (ATEX with K/C) 0°C to +90°C (ATEX with T/S)
Process pressure	6 bar (10 bar temporarily)
Protection class	IP67
Output	RS485 to connect with HUMY/ SCS 3000 control unit
Cable length	Shielded 4-pole cable, 3 meters as standard, any length up to 1000 meters on request
Dimension and weight	D100 mm x 51,5 mm, 1300 g

Technical Data HUMY 3000

Measured moisture	0-85 % residual moisture or 15-100% dry substance (TR)
Indicator	Percentage value with max. 3 decimal places
Accuracy	Up to 0,1 % (depending on the product)
Average & Filter Value	0 - 999 seconds
Savable Calibration	Up to 24 calibration curves
Data Logger	Storage of moisture and temperature with time and date. 1 GB with 1 s scan rate is enough for 2 years
Ambient temperature	-10°C to +60°C
Protection class	IP20 IP65 (optional)
Supply voltage	115 / 230 VAC with -15 % to +10 %; 24 VDC with +/- 25 %; max. 6 W
Input	1x RS485 (from sensor), 2x digital input (8 - 36 VDC; 2 - 14 mA) 1x external Pt100
Output	2x Analog for moisture & tem- perature (0/4-20 mA; 0-10 V), 2x Relay for max / min alarm (62,5 VA / 30 W, max 125 VAC / 110 VDC, <1A) 2x Transistor for max / min pre-alarm (<1,4 W, <28 VDC, <50 mA) with free configurable delay (0-9,9 sec) and hysteresis (0-99,9 %), NO or NC 1x RS485 with MODBUS protocol, USB via interface cable
Dimension & weight	236 x 132 x 330 mm; 4500 g

